



DESIGN OF QUARD COPTER USING KK MULTICOPTER UNIT

Dr. E Venkatesh¹, M. Vandhana², S. Tejaswini³, P. Komali Keethana⁴

¹ Assistant Professor, Dept. of EEE, Malla Reddy Engineering College for Women, Hyderabad.

^{2,3,4} Research Student, Dept. of EEE, Malla Reddy Engineering College for Women, Hyderabad

ABSTRACT

Drone (drone) is a remote controlbased electronic device used to maintain vertical stability using the KK2.1.5 board, can be used for social media nature or to capture images using a camera, and can be great in technology to improve performance and reduce the cost of microcontrollers so that citizens can make their own drones. The equipment is connected to the speed control, transmitter, receiver, lithium battery and camera. All products are controlled and controlled. The PID controller is adjusted and calibrated to ensure stability for each axis. Now the drone balances itself normally. The purpose of the project has been achieved, the image is stabilized and captured.

Keywords: Drone, KK2.1.5 board, Transmitter, Receiver, Motors, Camera. for Surveillance.

1. INTRODUCTION

A Drone has the potential for performing many tasks where humans cannot enter, for example, high temperature and high altitude surveillance in many industries, rescue missions. A Drone has four propellers with motors that generate, the thrust for lifting the aircraft. A drone is also called as the Quadcopter. The basic principle behind the quadcopter is, the two motors will rotate in the clockwise direction the other two will rotate in an anticlockwise direction allowing the aircraft to vertically ascend. While taking the flight with the help a camera we can have live streaming and capture images.

2. SYSTEM OVERVIEW

The system consists of KK2.1.5 Multi-rotor board, transmitter, receiver, Lipo battery, electronic speed controllers, motors, and frame.

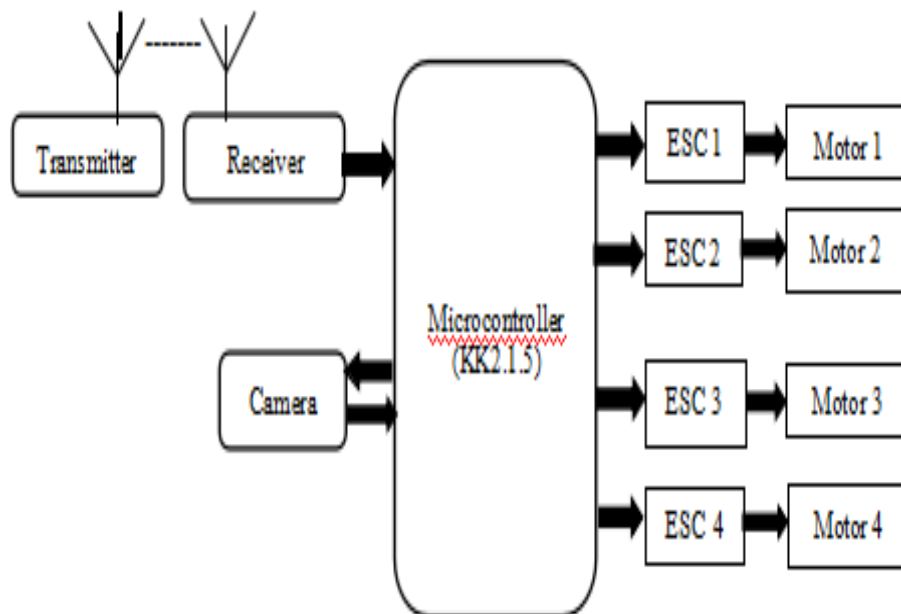

Fig 1: Block Diagram of the Drone



3. KK2.1.5

KK 2.1.5 is a board with ATMEL mega 664PA,8-bit AVR RISC based microcontroller with 64K of memory.It is easy for the beginner to start with and has firmware pre-defined in it. While activating or deactivating the board there is an audio warning from the piezo buzzer of KK 2.1.5.It is the most stable board because it has inbuilt gyroscope, 6050 MPU, and auto level function. This board has eight motor outputs, five control inputs, an LCD display, polarity protected voltage sensor input, an ISP header, six-axis accelerometer/gyroscope, a fuse protected piezo output. The user-defined signals from K.K.board are processed by ATMEL 644PA IC and these control signals are passed to the ESC's installed on the frame of the drone.

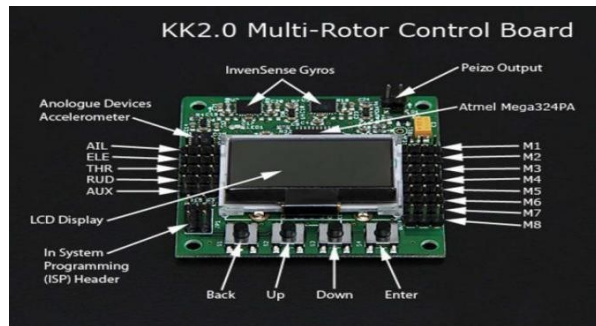

Fig 2: KK 2.1.5 Flight Control Board

Table 1: Specifications of KK2.1.5 Board

Microcontroller	Atmega 664PA
Operating voltage	1.8-5.5V
Input voltage	4.8-6.0V
Gyro./Acc.	MPU 6050
Memory	64KBytes
Signal from Receiver	1520us(5channels)
Signal to ESC	1520us
Pin count	44
Software required	Pre-installed
Size	50.5mm X 50.5mm X 12mm

4. ELECTRONIC SPEED CONTROLLER

An electronic speed controller is an electronic device used to control the speed of the motor and the direction also. It follows a speed reference signal and varies the switching rate of field effect transistors. By adjusting the duty cycle or switching the frequencies of the transistor the speed can be changed.



Fig 3: Internal Circuit of Electronic Speed Controller



Fig 4: Electronic Speed Controller

Table 2: Specifications of Electronic Speed Controller

Output	25A per 10 seconds
Input	35A per 10 seconds
Input voltage	2-4 cell Lipo battery
Weight	23 gms
Max Speed	2 pole-210k rpm

5. BRUSHLESS DC MOTOR

DC motor is a type of synchronous motor that is powered by DC source via an inverter to produce an AC electric current to drive each phase of the motor. Its construction is simple as permanent magnet synchronous motor. The advantage of this motor is High speed and electronic control.



Fig 5: Brushless DC Motor

Table 3: Specifications of Brushless DC Motor

Kv(rpm/v)	1000
Max.Power	920W
ESC	30A
Weight	150 gms
Battery	3S-5S Lipo

6. PROPELLERS

These are simply fans which convert the motion of the motor into upward thrust. They are, made up of flexible fibre to be unbreakable while crash landing.



Fig 6: 10 X 4.5 inches Propellers



Table 4: Specifications of Propellers

Inches	10inch
Thickness	0.45 inch
Diameter	0.8 inch
Weight	22 gms
Type	Pusher &puller pair

7. BATTERY

Lithium polymer battery or Lipo battery is a simple rechargeable battery with different current ratings and number of cells. Here lithium ion adds to the polymer which is an electrolyte.



Fig 7: Lipo battery

Table 5: Specifications of Lipo Battery

Type	Lipo
No. of cells	3S (3cells)
mAh	3500mAh
Output Voltage	11.1V
weight	400 gms

8. TRANSMITTER & RECEIVER

The Transmitter acts as a controller from the user. It is a radio communicating wireless control system. The signal from the transmitter is received by the receiver placed on the frame of Drone through the antenna in a receiver. The signal from a receiver is given to KK board. This board will send the signal to all electronic speed controller from that speed of the motor is controlled by the transmitter. The modulation scheme used in between transmitter and receiver is pulse position modulation (PPM).



Fig 8: FSCT-6B Transmitter and Receiver



Table 6: Specifications of Transmitter and Receiver

Type	FSCT6B
Frequency	2.4 GHz
channels	6
Operating voltage	10-12v
Receiver Weight	50 gms
Antenna	1

9. FRAME

These are many types of frames for Drone. They are made of fibre & has integrated PCB for soldering ESCs and battery wires. Different colour coding made us know the orientation of the Drone.



Fig 9: Drone PCB Frame

Table 7: Specifications of Drone Frame

Frame	X shape
Width	450mm
Height	55mm
Weight	280 gms
Motor mounting holes	16

10. CAMERA

A Camera is used for live streaming & capturing images during a flight of drone. There are many types of cameras for the purpose Like professional, racing HD cameras.



Fig 10: Camera for Surveillance



Table 8: Specifications of Camera

Mega pixel	3p
Resolution	720P
Application	Surveillance

11. WORKING

As the battery (Lipo) is plugged into the power distribution board of drone, here camera is also switched ON for live streaming and capturing pictures. Before this, the Transmitter should be in ON condition, if not ERROR can occur in FCB. After switching ON the FCB and the Transmitter, the Receiver test is done to make every channel that is Aileron, Throttle, Elevator, Rudder, Aux equal to " 0 ". Now after the receiver test, ARM the K.K 2.1.5 board so that all 4 motors rotate with equal orientation and speed. Now increase the Throttle using Transmitter (controller) to stabilize the motor's speed and take a flight.

12. RESULT



Fig11: Rare view of Drone



13. FLOWCHART

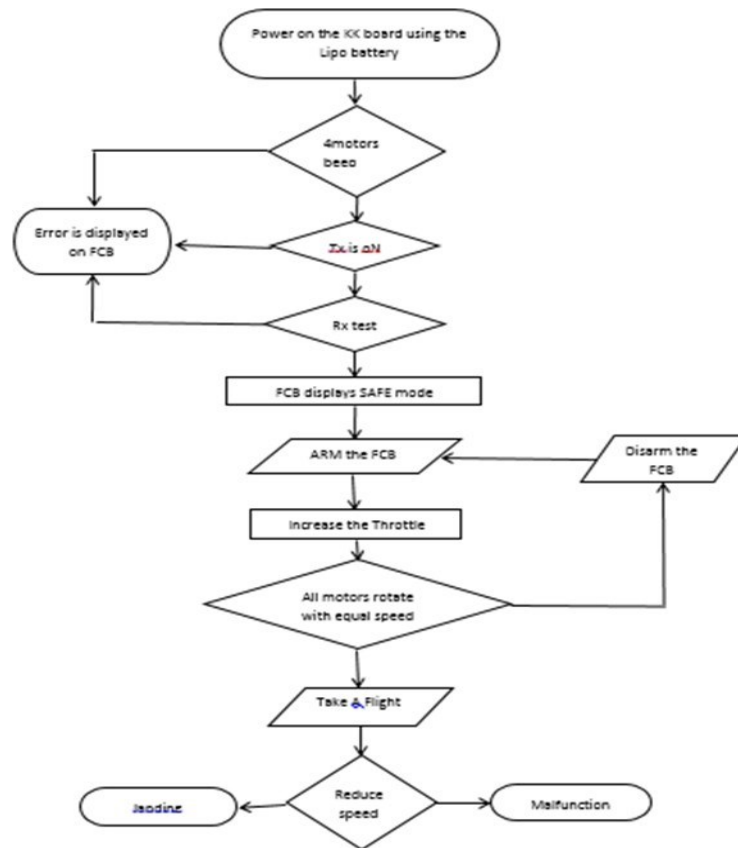

14. PRECAUTIONS

- Before switching ON the KK2.1.5 make sure the Transmitter is in ON condition.
- Do the receiver test that is making sure the Aileron, Elevator, Rudder, throttle, Aux pins are all equal to zero.
- At last, check if all the motors are rotating with equal speed or not if you are increasing the Throttle value.
- Make sure that the Lipo battery is fully charged up to 11.1V
- Lipo batteries are highly dangerous, there is a chance for it to explode if they are overcharged. So be careful while charging them. Don't leave it unattended while charging.

15. CONCLUSION

There are many places where man has to risk his life for the surveillance in industries like in horrible temperature conditions unbearable by man, high altitude work. There are many people losing their lives. So the solution to this problem can be brought up by using a remote-controlled aerial vehicle for surveillance.

This project majorly finds its use in military and defense for surveillance at the border as a part of border security force and can reduce the loss of human lives by intimating the soldiers about the target.

16. REFERENCES

- [1] R. Banga "Building a Quadcopter using KK 2.1.5 Flight Controller" in Instructables published on June 27th, 2015.
- [2] Craigie "FPV for Beginners" in Drone fliers and published on October 10th 2014.
- [3] Korey "How to Build a Quad copter" in My First Drone.published on February 22nd,2014.
- [4] Coleman Benson "How to Make A UAV/Drone" in Robot Shop published on October 29th,2014.
- [5] Clym Montgomery "Multi-Rotor, First-Person view, And The Hardware You Need" in tom shard ware published on June 3rd, 2014.